

## EQACC SOLAR

# How much does Huawei s industrial and commercial energy storage cabinet cost



## Overview

---

What is Huawei C&I storage?

Huawei's C&I storage systems are certified for both low voltage and medium voltage grid connection and are redefining the ESS landscape, together with the LUNA2000 series and with Smart PCS LUNA2000-100KTL-M1 100 kW converter. Offering innovative battery management solutions, Huawei has placed emphasis on safety and performance optimization.

What makes Huawei a good battery management company?

Offering innovative battery management solutions, Huawei has placed emphasis on safety and performance optimization. Batteries are the heart of every storage system and are also subject to risks such as over- and under-discharge or over- and under-temperature.

How much does a commercial lithium battery energy storage system cost?

In 2025, the typical cost of a commercial lithium battery energy storage system, which includes the battery, battery management system (BMS), inverter (PCS), and installation, is in the following range: \$280 - \$580 per kWh (installed cost), though of course this will vary from region to region depending on economic levels.

How many machines can be installed in a Huawei C&I system?

These storage systems are very flexible, up to 5 machines can be installed in the same system, in this way there is scalability from approximately 97 to 970 kWh in steps of 30 kWh. The combination with string inverters from the Huawei C&I segment occurs naturally with a single supervision system.

## How much does Huawei s industrial and commercial energy storage

---



### Energy storage cabinet sales price inquiry table

How much does gravity based energy storage cost? Looking at 100 MW systems,at a 2-hour duration,gravity-based energy storage is estimated to be over ...

---

### The Real Cost of Commercial Battery Energy ...

With fluctuating energy prices and the growing urgency of sustainability goals, commercial battery energy storage has become an ...



---

### C& I Energy Storage Cabinet

A C& I Energy Storage Cabinet is a fully integrated solution designed to store and manage energy for commercial and industrial applications. These systems help stabilize power supply, ...



---

### Energy Storage Cabinet Cost Analysis: What You Need to ...

Who Cares About Energy Storage Cabinet Costs? (Spoiler: Everyone) Let's face it--energy storage cabinets are the unsung heroes of our renewable energy revolution. ...



### Huawei's C& I storage systems

Huawei's C& I storage systems are certified for both low voltage and medium voltage grid connection and are redefining the ESS landscape, together with the LUNA2000 ...

### Huawei introduces industry-first hybrid ...

Huawei Digital Power has launched the FusionSolar C& I LUNA2000-215-2S10 Energy Storage System, designed to meet the ...

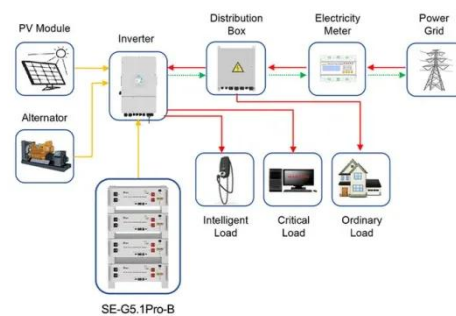

Application scenarios of energy storage battery products

### How much does Huawei's energy storage cabinet cost?

Investing in Huawei's energy storage cabinet involves more than simply considering its monetary outlay; it encompasses a thoughtful evaluation of

multiple intrinsic and extrinsic ...



---

## The Real Cost of Commercial Battery Energy Storage in 2025: ...

With fluctuating energy prices and the growing urgency of sustainability goals, commercial battery energy storage has become an increasingly attractive energy storage ...



---

## Huawei introduces industry-first hybrid cooling energy storage ...

Huawei Digital Power has launched the FusionSolar C& I LUNA2000-215-2S10 Energy Storage System, designed to meet the dynamic demands of the commercial and ...

---

## How Much Does Commercial Energy Storage Cost?

In this article, we break down typical commercial energy storage price ranges for different system sizes and then walk through the key cost drivers behind

those ...



---

### Huawei's C& I storage systems

Huawei's C& I storage systems are certified for both low voltage and medium voltage grid connection and are redefining the ESS ...



---

### Energy Storage System Products List , HUAWEI Smart PV ...

Energy Storage System Products List covers all Smart String ESS products, including LUNA2000, STS-6000K, JUPITER-9000K, Management System and other accessories product series.



---

### How much does Huawei's energy storage ...

Investing in Huawei's energy storage cabinet involves more than simply considering its monetary outlay; it encompasses a thoughtful ...



---

## Industrial Cabinet Storage

The Industrial Cabinet Storage is a premium choice in the Filing Cabinets category. Buying filing cabinets wholesale provides cost savings, bulk order options, and consistent product quality.

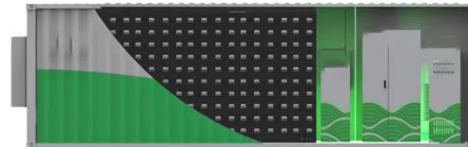

---

## Contact Us

For catalog requests, pricing, or partnerships, please visit:  
<https://www.eqacc.co.za>